

ata Abdominal



8019 ata Abdominal
Monteringsanvisning

ata

Før du monterer dette apparatet er det noen få ting som er lurt å ha kjennskap til:

1. Vi er klar over at bobleplast rundt hele apparatet ikke er kjempegøy å fjerne eller kanskje vinner årets designpris, men foreløpig er det den beste måten vi har funnet for å beskytte ditt apparat fra skader under transport.
2. Ditt apparat har vært montert i vår kvalitetskontroll. Det betyr at alt passer, selv om det noen ganger kan være litt vanskelig eller føles som om ting ikke passer helt under selve monteringsprosessen. Det er viktig å huske på at du ikke skal stramme alt med en gang du fester det - som regel strammer vi ikke før alt er på plass. Da vil du også merke at monteringen blir enklere.
3. Ripper og skader på rammen – dette har noen ganger skjedd selv om vi har brukt bobleplast, eller så kan det noen ganger skje hos deg under opppakking og/eller monteringsprosess. Ikke fortvil! Vi har farge på lager som vi kan sende til deg, slik at ripene kan skjules.
4. Monteringsråd:
 - a. det er lurt å bære alle delene dit du skal montere for å ikke måtte løfte alt flere ganger. Pakk delene ut og lag deg en oversikt på alt du har og hvilke verktøy du kommer til å bruke. Et skrallesett kan vi garantere at du må bruke!
 - b. Når du trenger å bruke hammer; bruk en gummihammer.
 - c. Sørg for å være minimum to personer i de tunge prosessene. Det er ikke anbefalt å la vekten av apparatet henge i en bolt eller gjenge.
 - d. Vi pleier å bruke Boxjump (plyoboks) som «stige».
 - e. Godt humør og kjærlighet er anbefalt!

Ps. Dersom dere har flere apparater å montere, vil en stor del av jobben være å pakke alt opp, fjerne bobleplasten og legge delene på riktig sted. Dette er altså oppgaver du kan be andre hjelpe deg med. Selv de som har null erfaring fra montering vil raskt kunne gjøre klart for montering og en stor del av oppgaven vil allerede være unnagjort!

Lurer du på noe som helst eller trenger hjelp så er det bare å ta kontakt! Vi gjør vårt aller beste for å støtte opp. Tel. 66101400 eller på info@atatreningsutstyr.no

Dersom du ombestemmer deg og heller vil ha full monteringshjelp, kan du også kontakte oss. Vi har interne montører i tillegg til at vi samarbeider med monteringsfirmaer i hele landet, slik at vi kan støtte opp med den hjelpen du trenger ved behov.

CONTENTS

01/IMPORTANT NOTICE

02/ ASSEMBLY PROCEDURE AND BILL OF MATERIALS

03/PRODUCT DESCRIPTION

04/PRODUCT PARAMETER

05/MAINTENANCE GUIDELINE

06/TROUBLESHOOTING

07/WARRANTY INSTRUCTION

01/IMPORTANT NOTICE

Thank you for choosing our machine, proper use of the machine is important to keep you convenient and away from danger. Please read the instruction before operating the machine:

1. Please read all user manuals before operating the machine and operate the machine according to the instructions. Please keep the user manual until the machine is scrapped.
2. Keep users read and understand all cautions
3. Keep air fresh, flowing and enough motion space for users when operating the machine.
4. Keep the machine in good condition. Ensure all fixed parts are tightened without extra parts. Inspect the parts easy to wear out regularly.
5. Please contact the dealer or after-sales department to change wear-out or defective parts. DO NOT operate the machine when it out of use.
6. Please wear proper sports dress and gym shoes before operating it, DO NOT wear skirt, jewelry and tie up the hair to avoid any possible dangers.
7. Do warm-up exercises before operating the machine.
8. Stop workout and ask your doctor when any abnormal symptoms occur such as headache, pain or emesis, etc.
9. Children must exercise under the supervision of adults.
10. WARNING: Keep hands and feet away from moving parts.
11. WARNING: DO NOT beyond adjustable setting range.
12. WARNING: Keep children or pets away from the machine when operating it.
13. WARNING: Keep all control apparatus in proper position.
14. WARNING: Please operate the machine in proper way, improper operating may not achieve workout effect of the machine, and lead to damage to your health.
15. Operating the machine in controlled area is recommended.

02/ASSEMBLY PROCEDURE

1) Step 1

Finished diagram

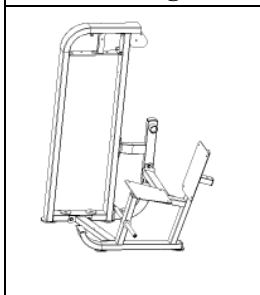

Bill of materials			
1	Gantry		1
2	Connection support 3		1
3	Connection support 4		1
4	Support frame		1
5	Connection support 2		1
6	Foam roller assembly		1
7	Outer hexagonal bolt	M12X25	12
8	Spring washer	Ø12	12
9	Drum washer	Ø12	12
10	Outer hexagonal bolt	M10X20	1

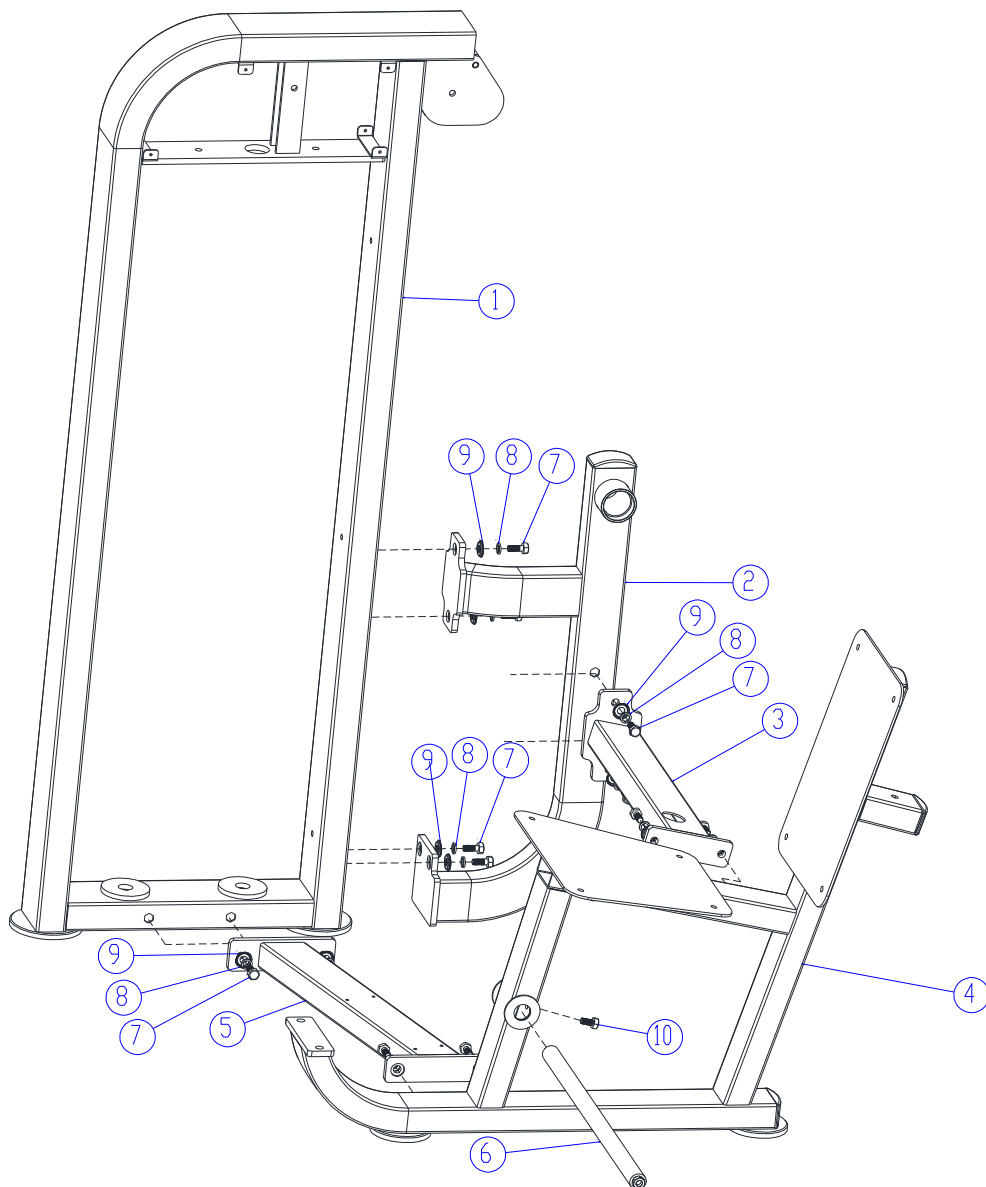

2) Step 2

Finished diagram

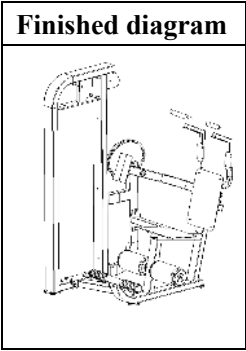

Bill of materials			
7	Outer hexagonal bolt	M12X25	2
8	Spring washer	Ø12	2
9	Drum washer	Ø12	2
11	Moveable arm assembly		1
12	Balance weight		1
13	Moveable arm assembly		1
14	Foam roller	Φ140*230	2
15	Footrest		1
16	Hexagon socket countersunk bolt	M12*40	2
17	Disc		1
18	Hexagon socket lock screw	M12*25	1
19	Hexagon socket flat head bolt	M12*25	1

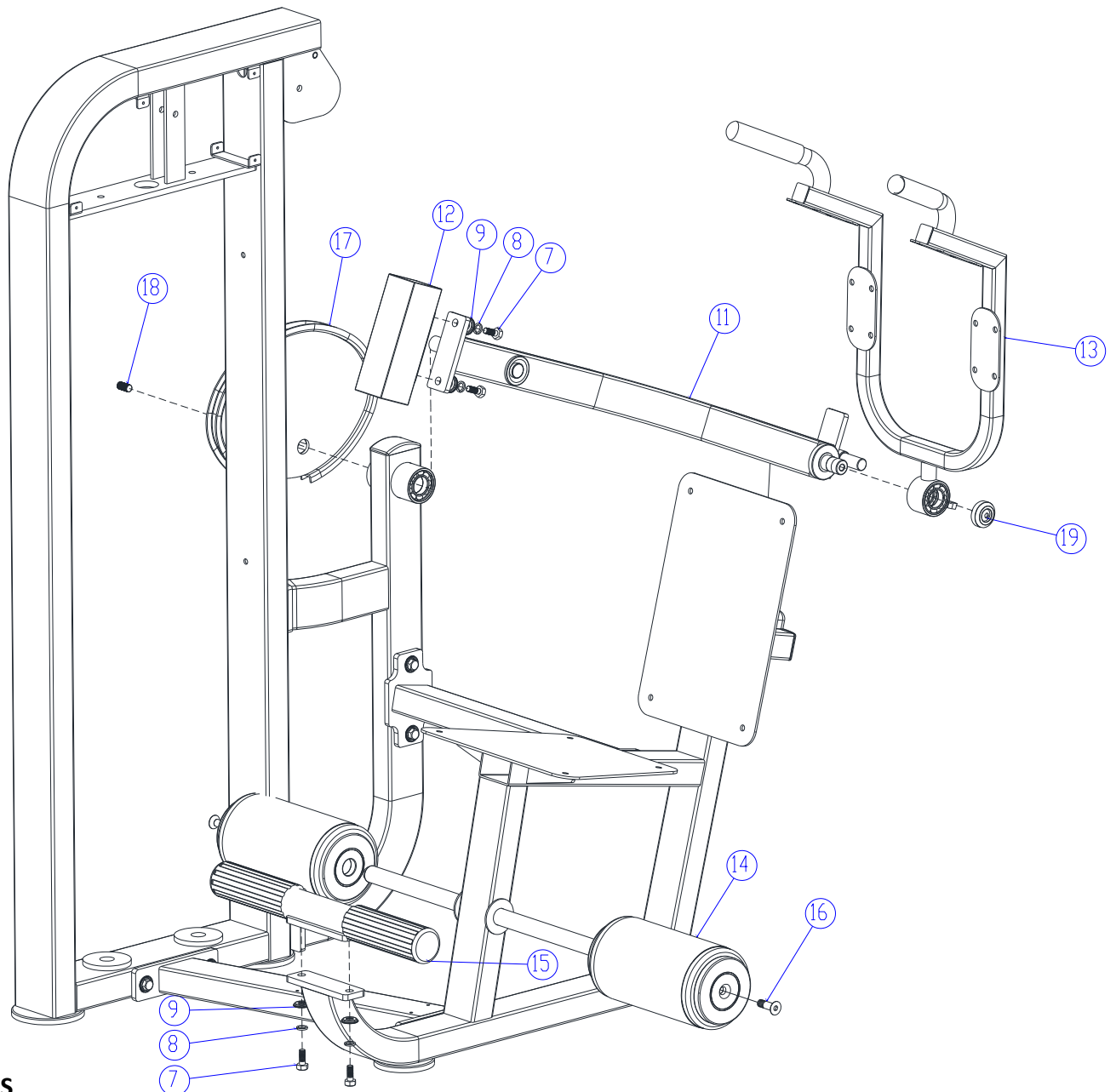

3) S

tep 3

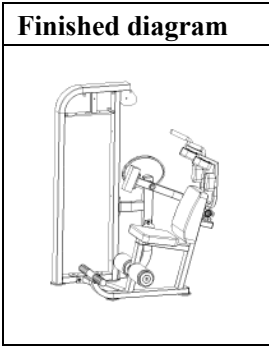

Bill of materials			
20	Back pad	420*300*120.3	1
21	Seat pad	400*320*60	1
22	Shoulder pad	150*80*60	4
23	Hexagon socket flat head bolt	M8*25	24
24	Spring washer	M8	24
25	Flat washer	M8	24

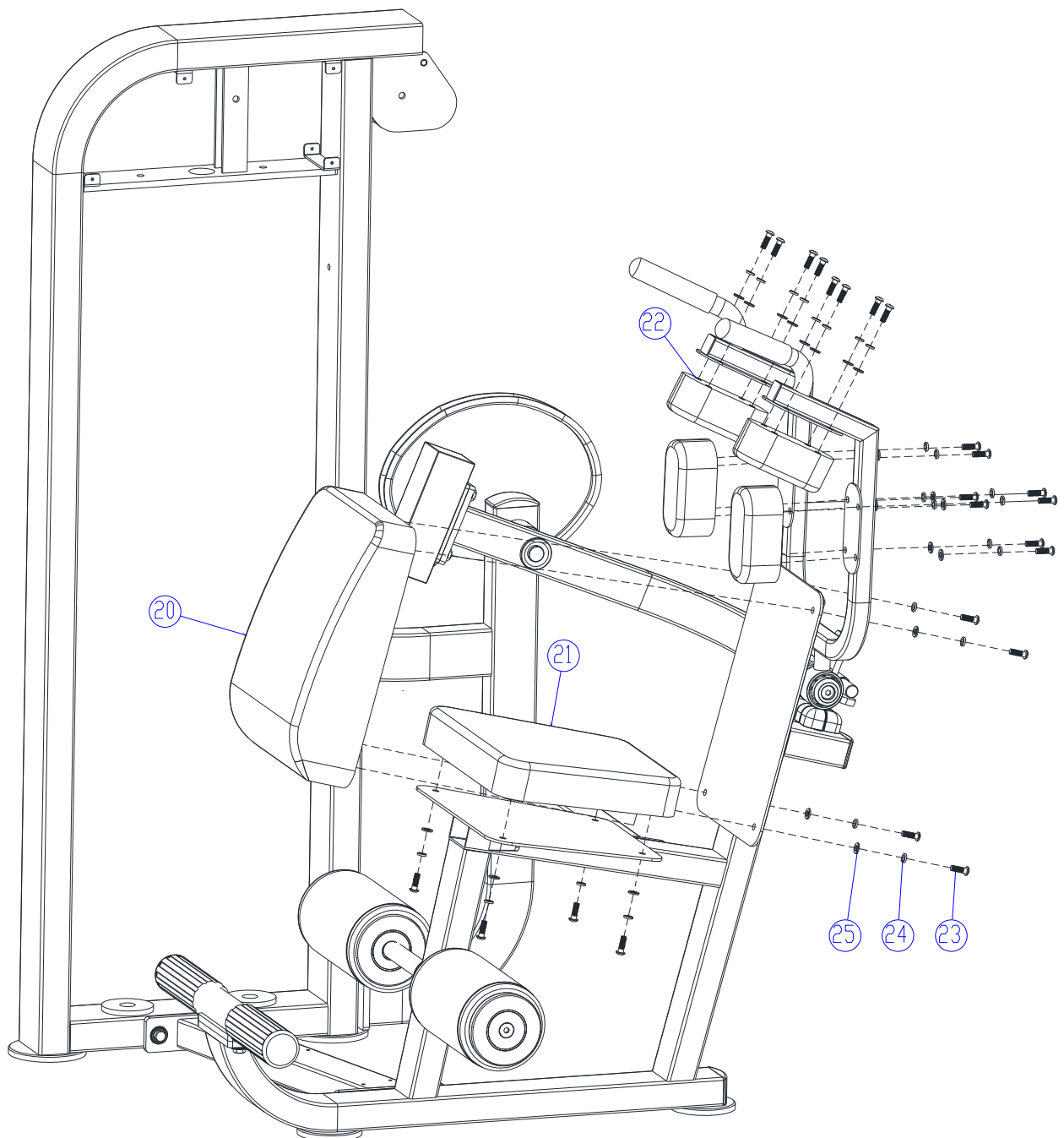

4) Step 4

Finished diagram

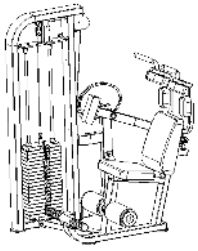

Bill of materials			
9	Drum washer	Ø12	2
23	Hexagon socket flat head bolt	M8*25	2
24	Spring washer	Ø8	2
25	Flat washer	Ø8	2
26	Guide rod fixed sleeve	Φ30*33	2
27	Guide rod	Φ20*1344	2
28	Weight stack		1
29	Pulley	Φ110*27.7	2
30	Cable	Φ6*1950	1
31	Hexagon socket lock screw	Φ8*10	4
32	Outer hexagonal bolt	Φ10*55	2
33	Flat washer	M10	2
34	Hexagon lock nut	M10	2

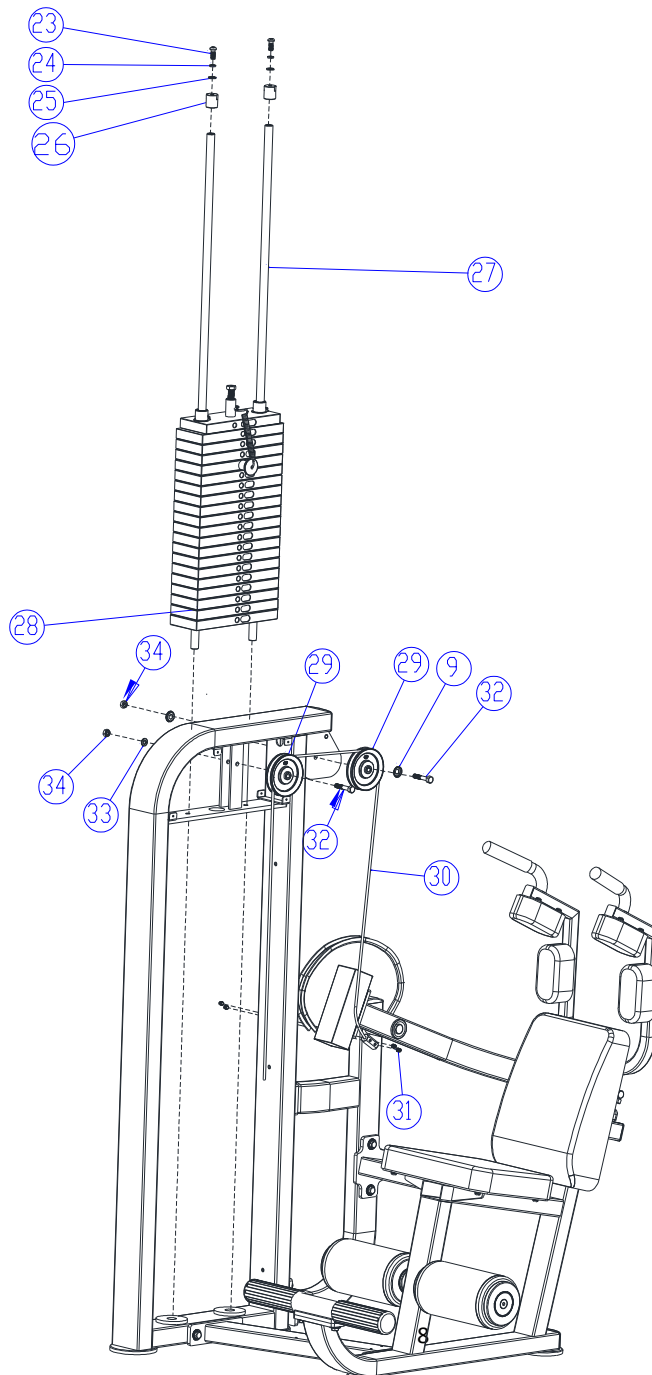

5) Step 5

Finished diagram

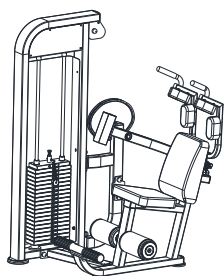

Bill of materials

Bill of materials			
24	Spring washer	M8	6
25	Flat washer	M8	6
35	Safety board	1240*621.4*T2	1
36	Training sticker	420*177*T1.2	2
37	Hexagon socket flat head bolt	M5*12	8
38	Hexagon socket cylinder bolt	M8*35	6

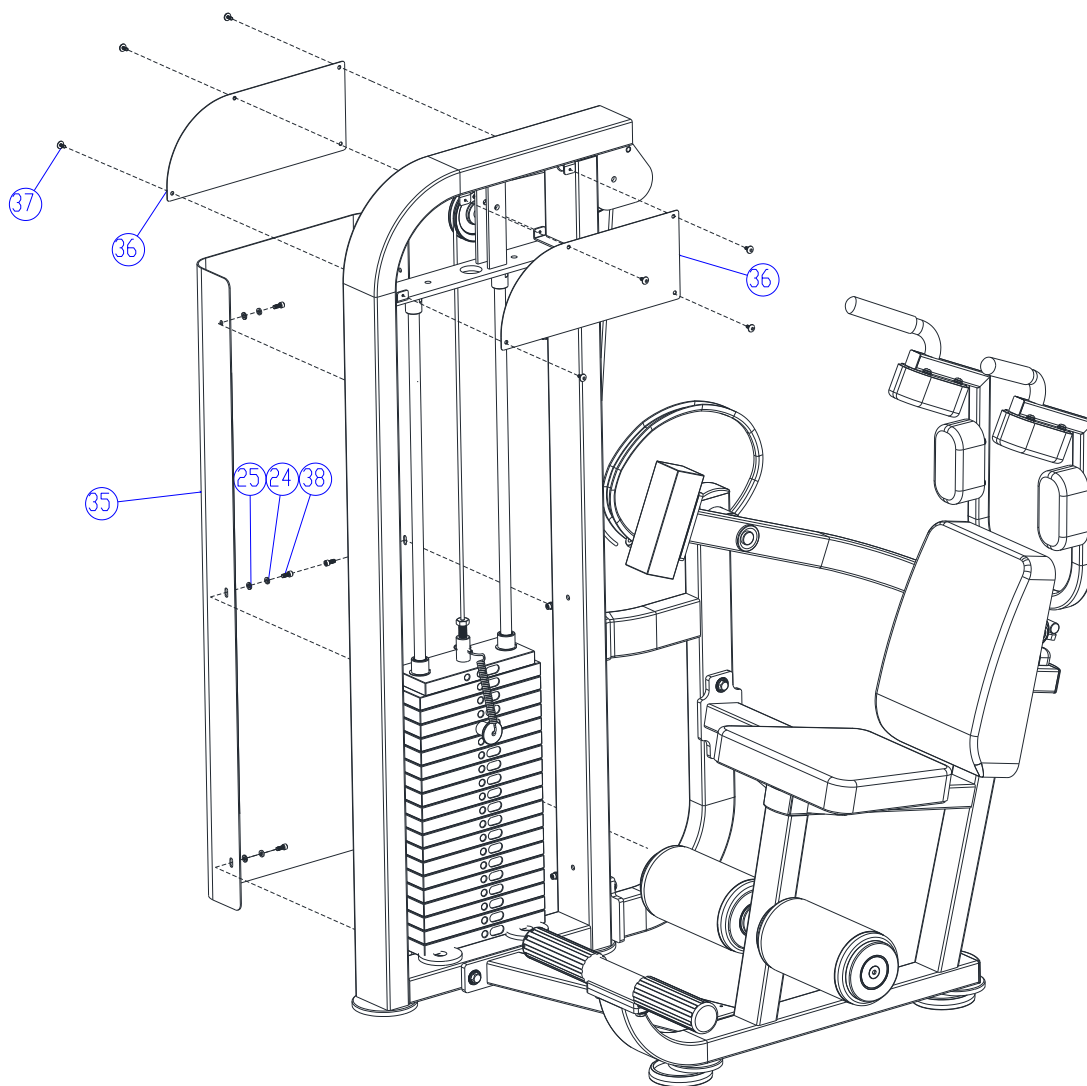

6) Step 6

Pulley installation instruction:

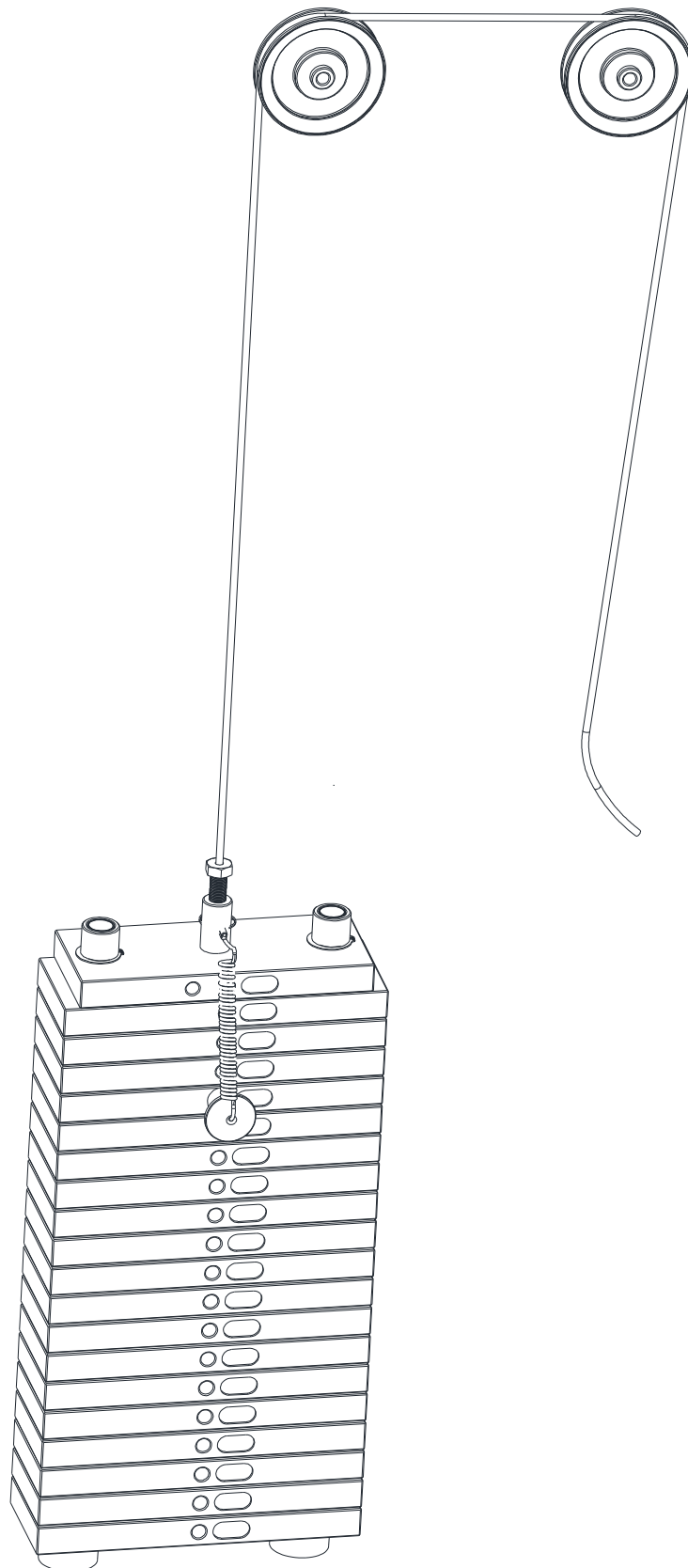

03/ PRODUCT DESCRIPTION

The machine is indoor fitness equipment, is suitable for aerobic exercise, mainly used to strength cardio-pulmonary function, and train the muscles supplemented. By workout with the machine pectorals and other muscles can be built up, achieve the purpose of bodybuilding and fitness.

The machine explains how to operate it properly and build up muscles by functional diagram, easy to learn. User can adjust the resistance by weight stack easily.

The design and manufacture of the machine meets the human motion curve, the safety and durability are guaranteed.

The design and manufacture of the machine meets the human motion curve, and meets the standard of GB17498.1-2008 and GB17498.2-2008, the safety and durability are guaranteed.

·Large size steel tube and electrostatic spraying guarantee the safety and durability.

04/ PRODUCT PARAMETER

Name	ata Abdominal	Model	8019
Floor space	1295*1009*1620	Weight stack	100Kg
Net Weight	220Kg	Category	Commercial

05/ MAINTENANCE GUIDELINE

1. All the bolts and screws should be inspected regularly and keep tightened; rotating parts should be flexible without abnormal sound.
2. The machine should be kept clean. Please DO NOT clean the machine with strong cleaning solvent.
3. Any worn or damaged stress parts should be repaired or changed immediately.

06/ TROUBLESHOOTING

Please contact support at 66101400 or info@atatreningsutstyr.no

07/ WARRANTY INSTRUCTION

1. Warranty scope

The machine is damaged by any non-impersonal factors under proper maintenance. The warranty card is valid only when the user is original buyer.

2. The warranty period is one year since buying the machine.
3. The below-listed damages are out of warranty:
 - 1). the damages caused by abuse, carelessness, accident or unauthorized modify.
 - 2). the damages caused by improper adjusting weight stack pin.
 - 3). the damages caused by improper maintenance.
 - 4). the damages caused by other violation operating.