

ata Rig Pro Elite

Cable Stack Add-on DUAL

Installation guide

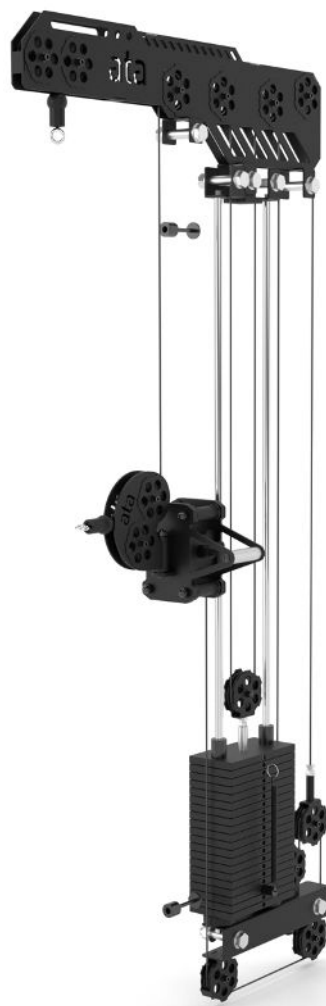

ASSEMBLY CAUTION

Assembling requires two persons

Do not tighten all screws before assembly is complete

Ensure that all accessories are complete. If not, please contact us: 66101400 /
info@atatreningsutstyr.no

To enhance your installation process for both speed and convenience, consider removing all accessories from the box, carefully opening the packaging, and arranging everything neatly on the floor. This preparation can streamline your setup experience.

Installation Examples

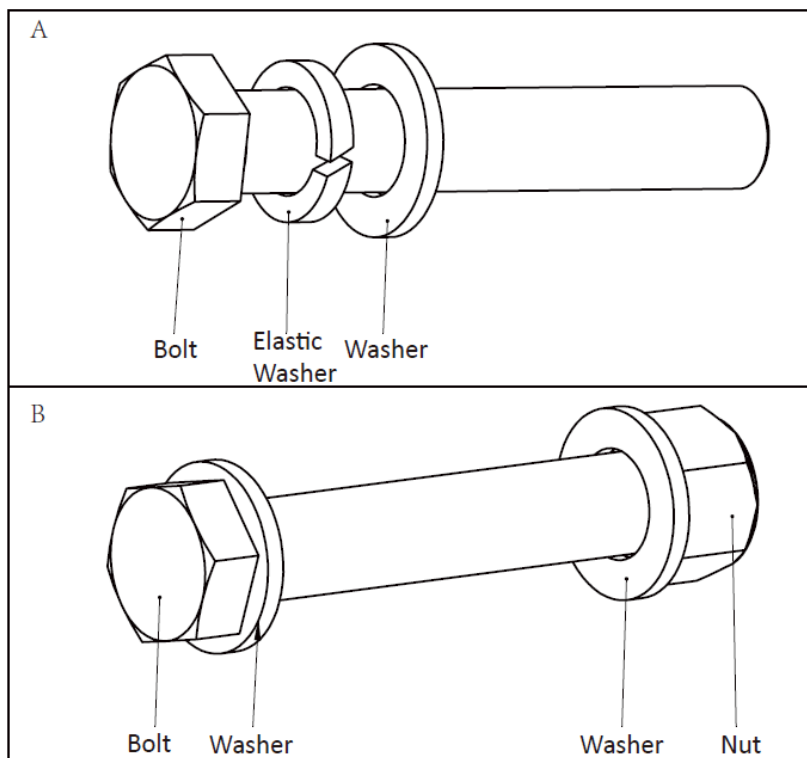

- Installation on an at Rack with Rig feet or Base Cross Bar, principals are the same.
- If you want to be able to move the rollers as far down as possible, you need to install on to a 220cm Up-Right.
- If you prefer the Lat Pulldown to be higher than you either need to use add-on 50/140cm or change to taller Up-Rights. 240cm for example.

STEP 1

Distinguish the left and right sides of rollers and add on to up-right

Choice of direction is up to you.

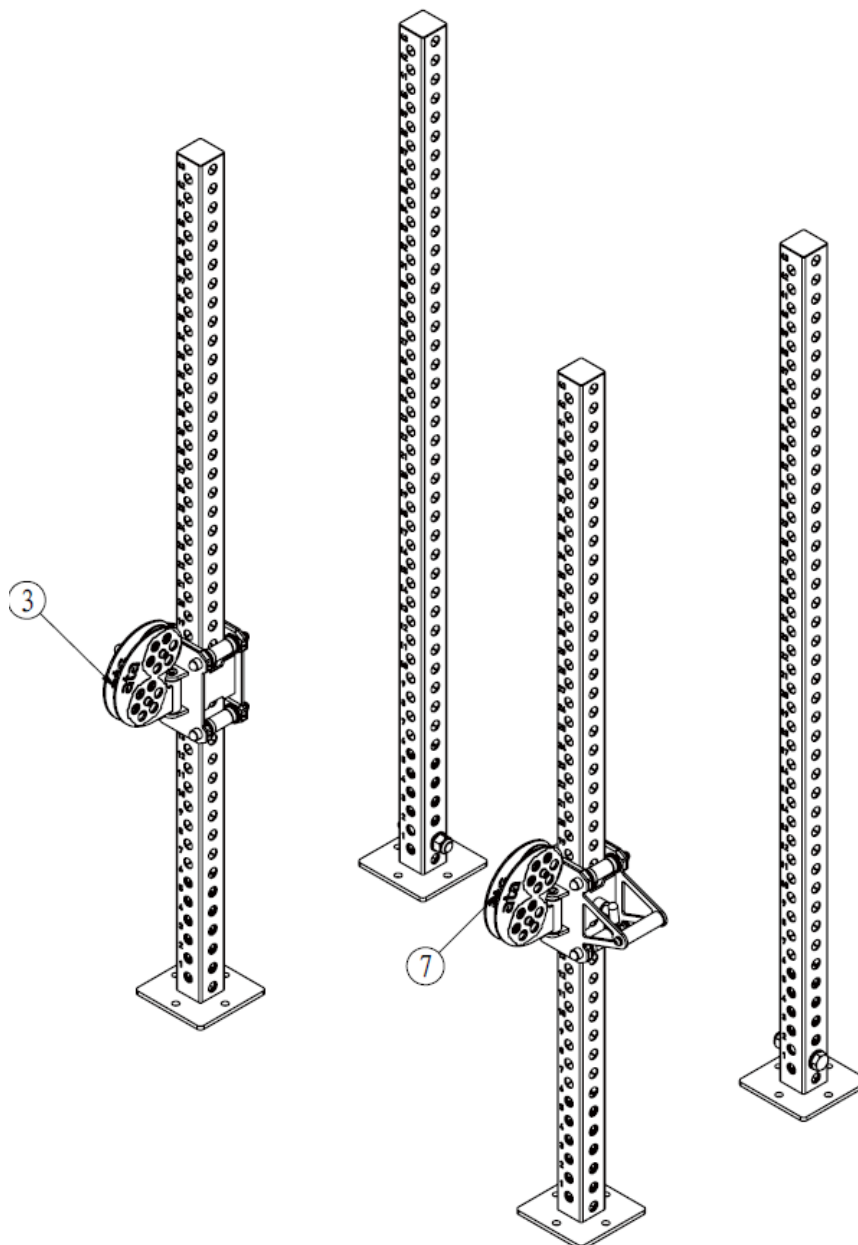

STEP 2 Connect the uprights with 60cm crossbars.

If you already have the Rig/Rack ready – please move to step 4. Note – the 60cm cross bars needs to be of our updated model to fit wire holes.

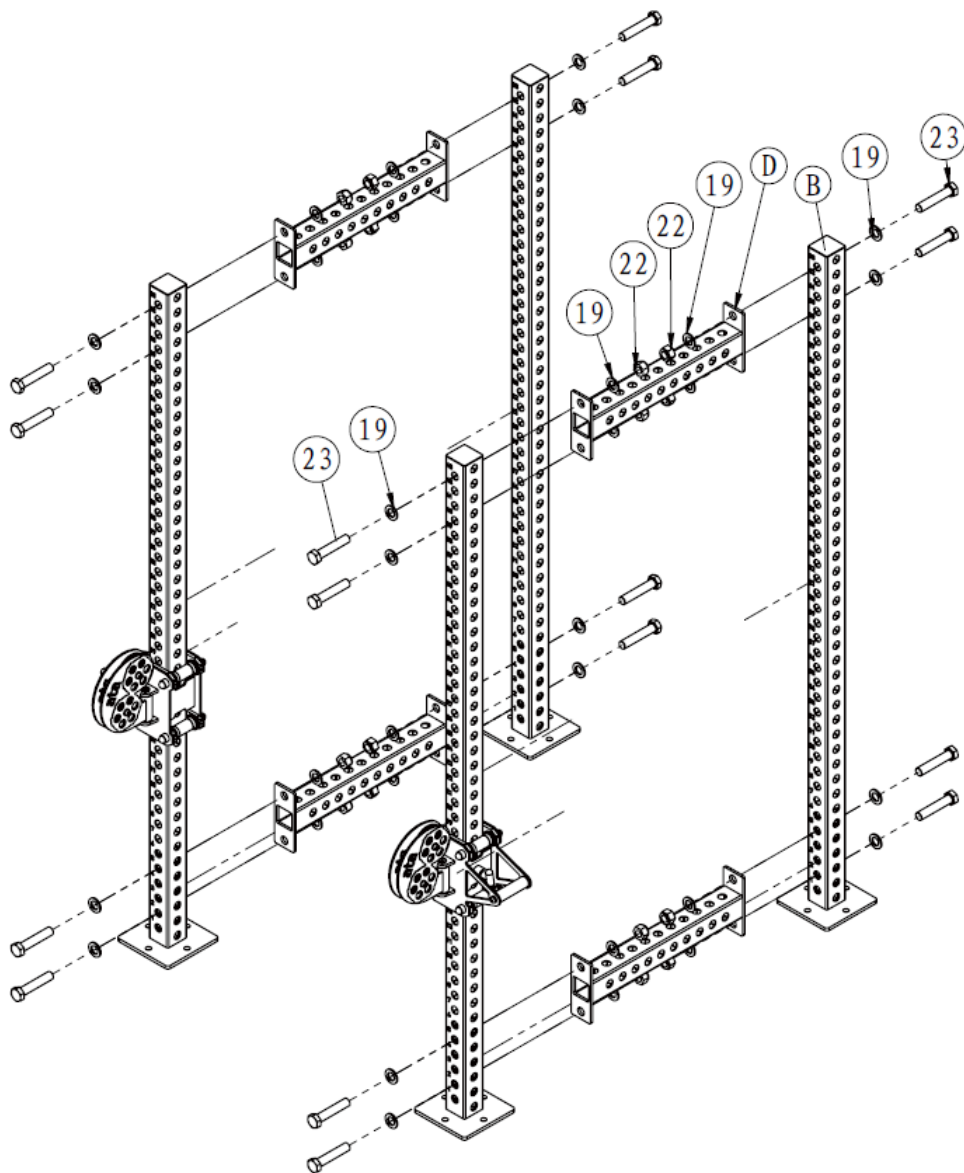

STEP 3 Make sure the up rights are connected with monkey bar / crossbars to keep installation secured and safe. If the Rig needs to be fastened to the floor – please make sure it is done so in this stage.

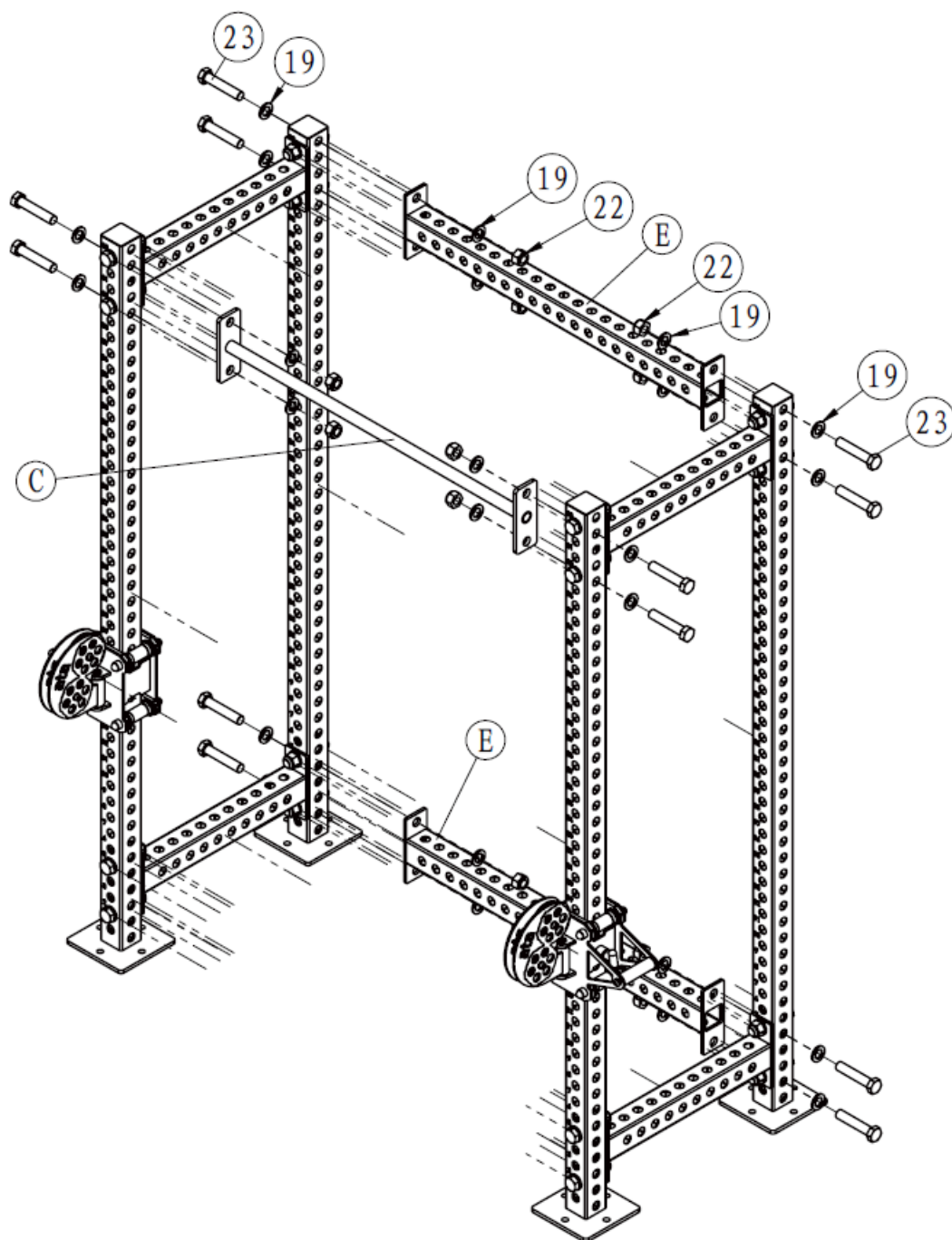

STEP 4 Install limit pins

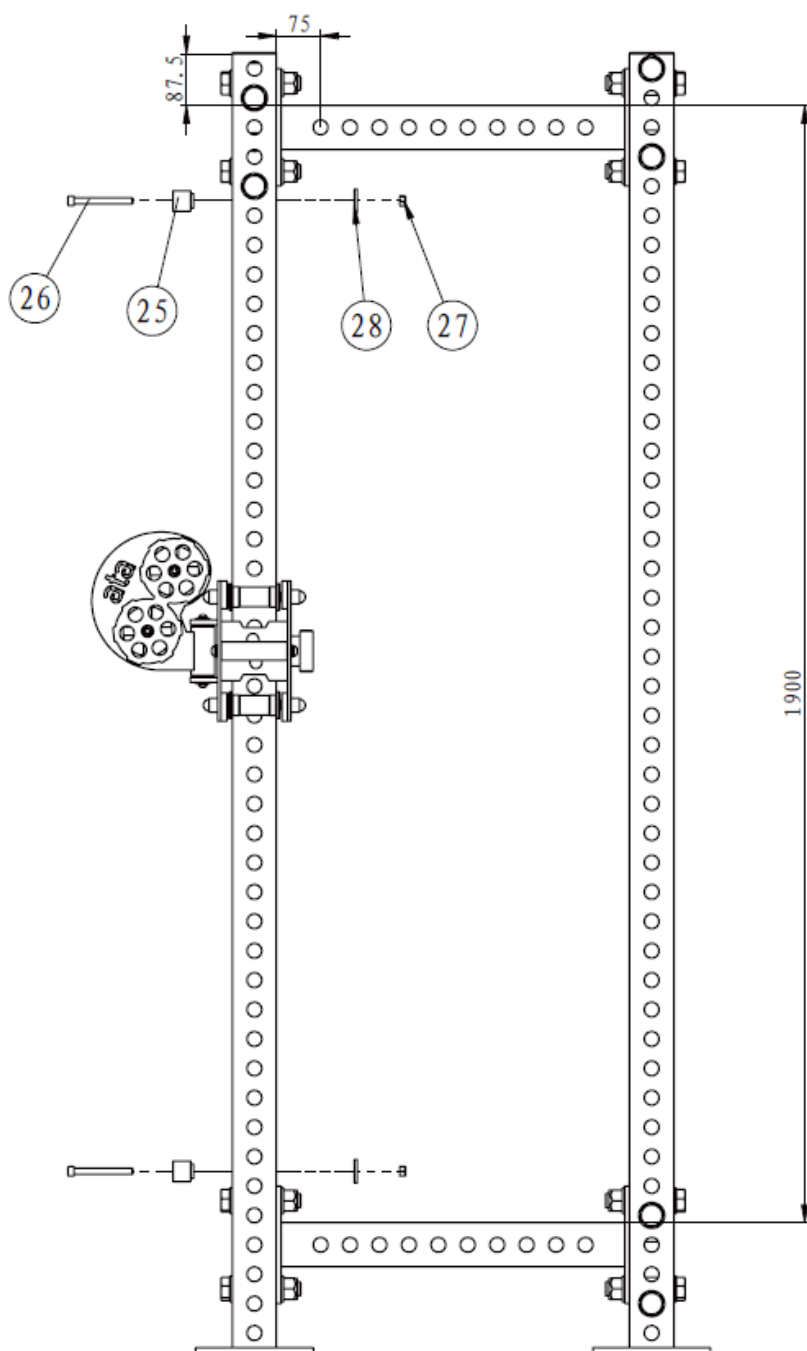

STEP 5 Install pulley parts

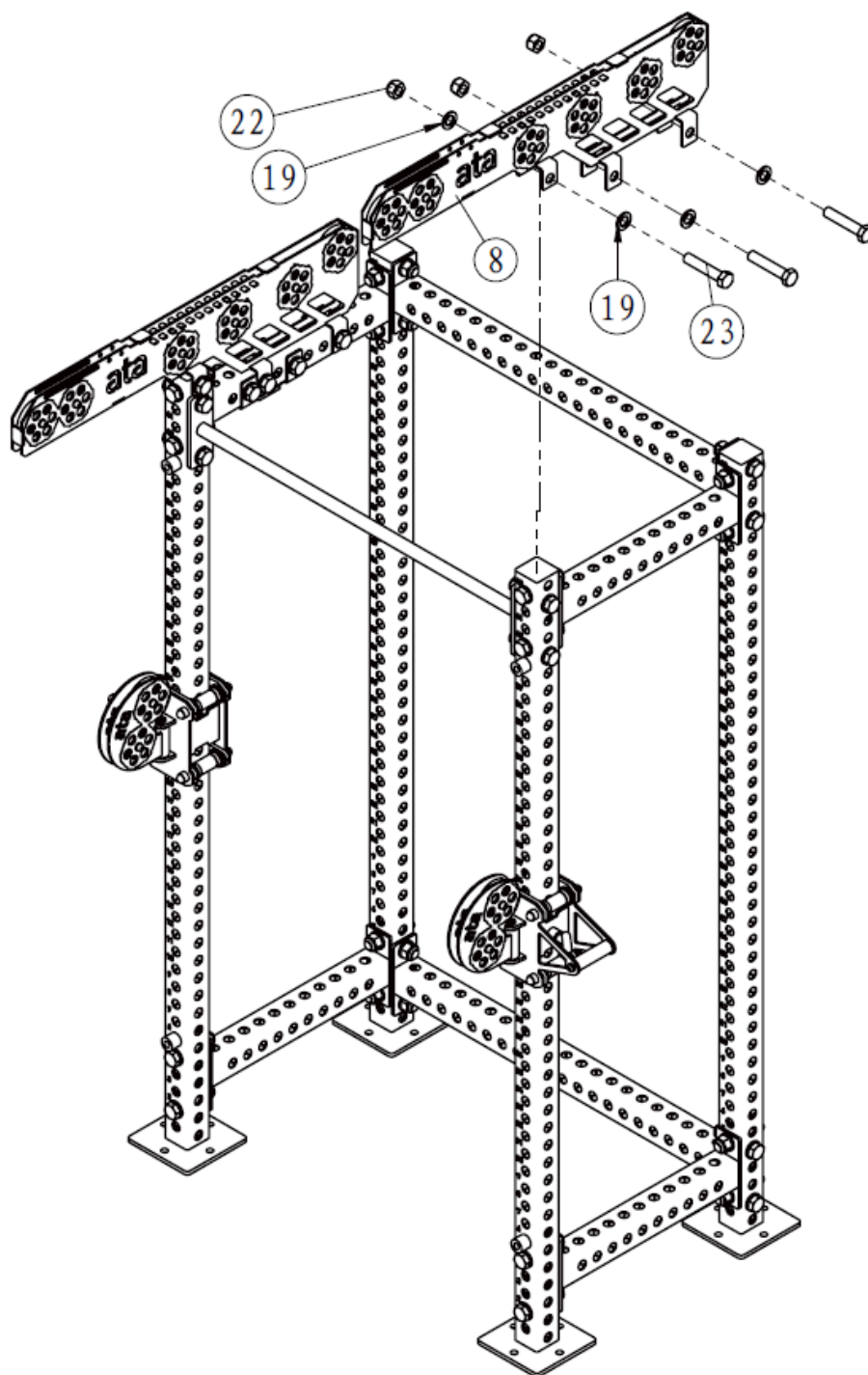

STEP 6 Install the bottom parts

Note: Distinguish the left and right sides.

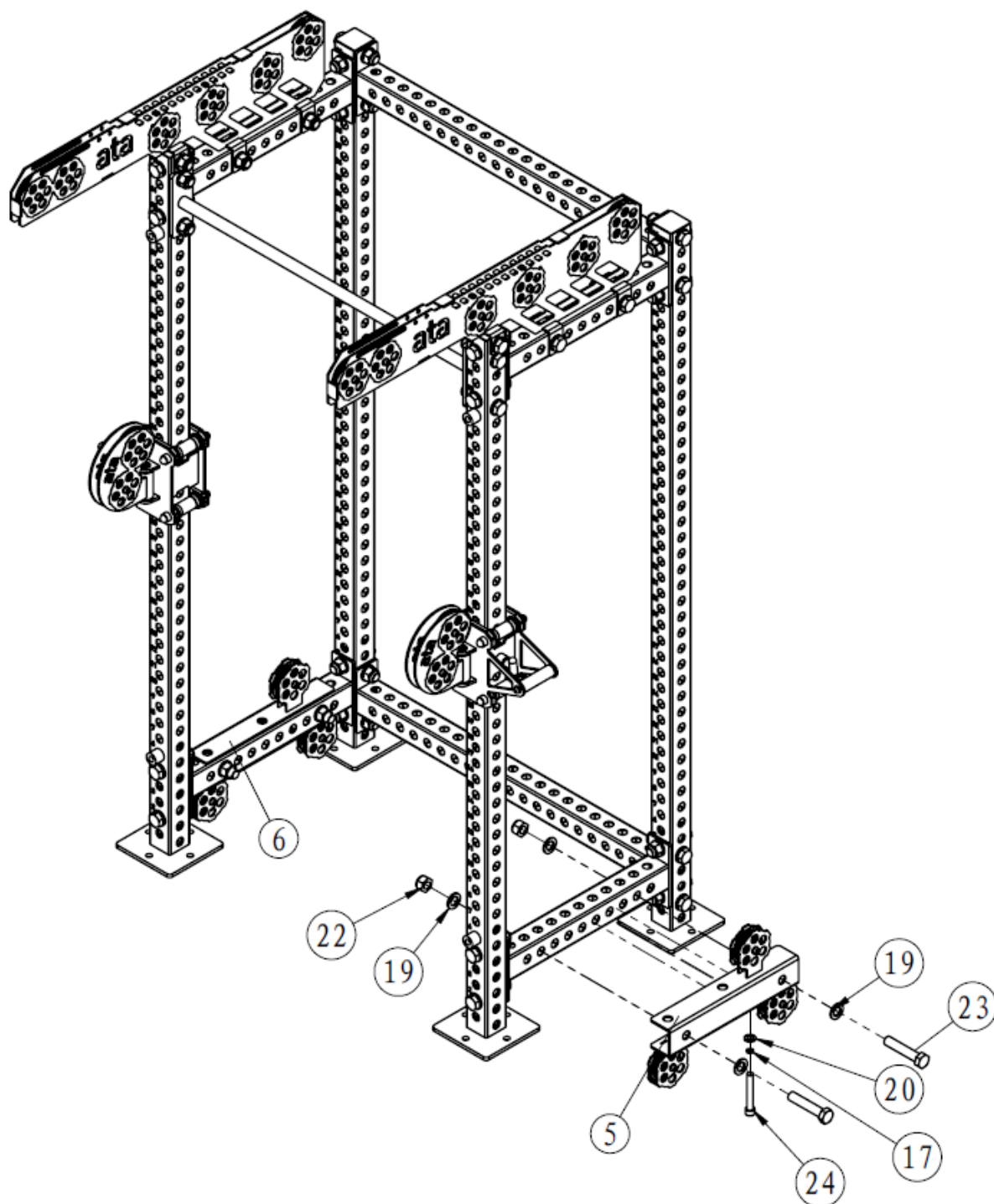

STEP 7 Install guide rods and weight stacks

You decide on which side the pin and KG marking goes.

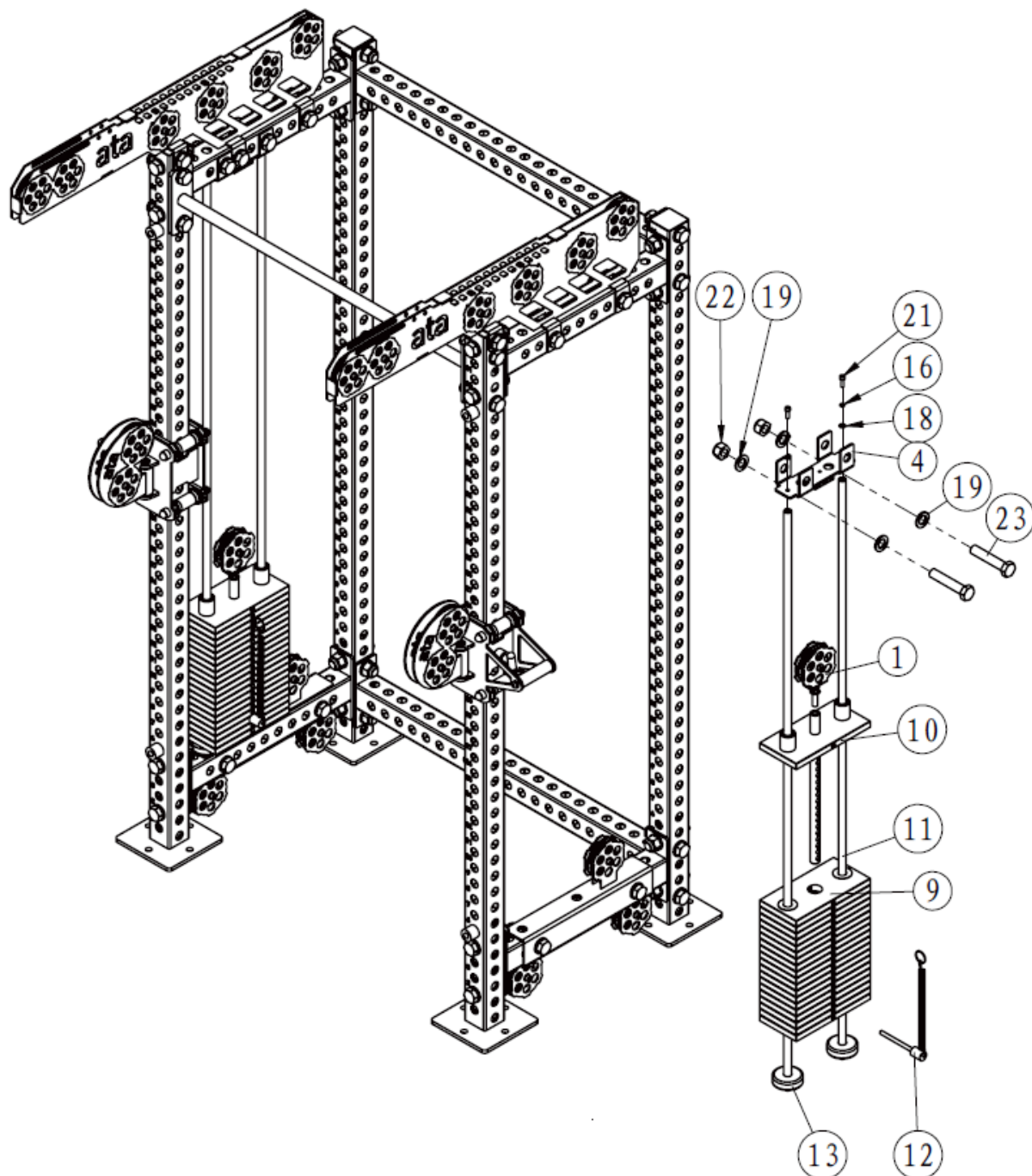

STEP 8 Install Lat Pulldown cable (the short cable)

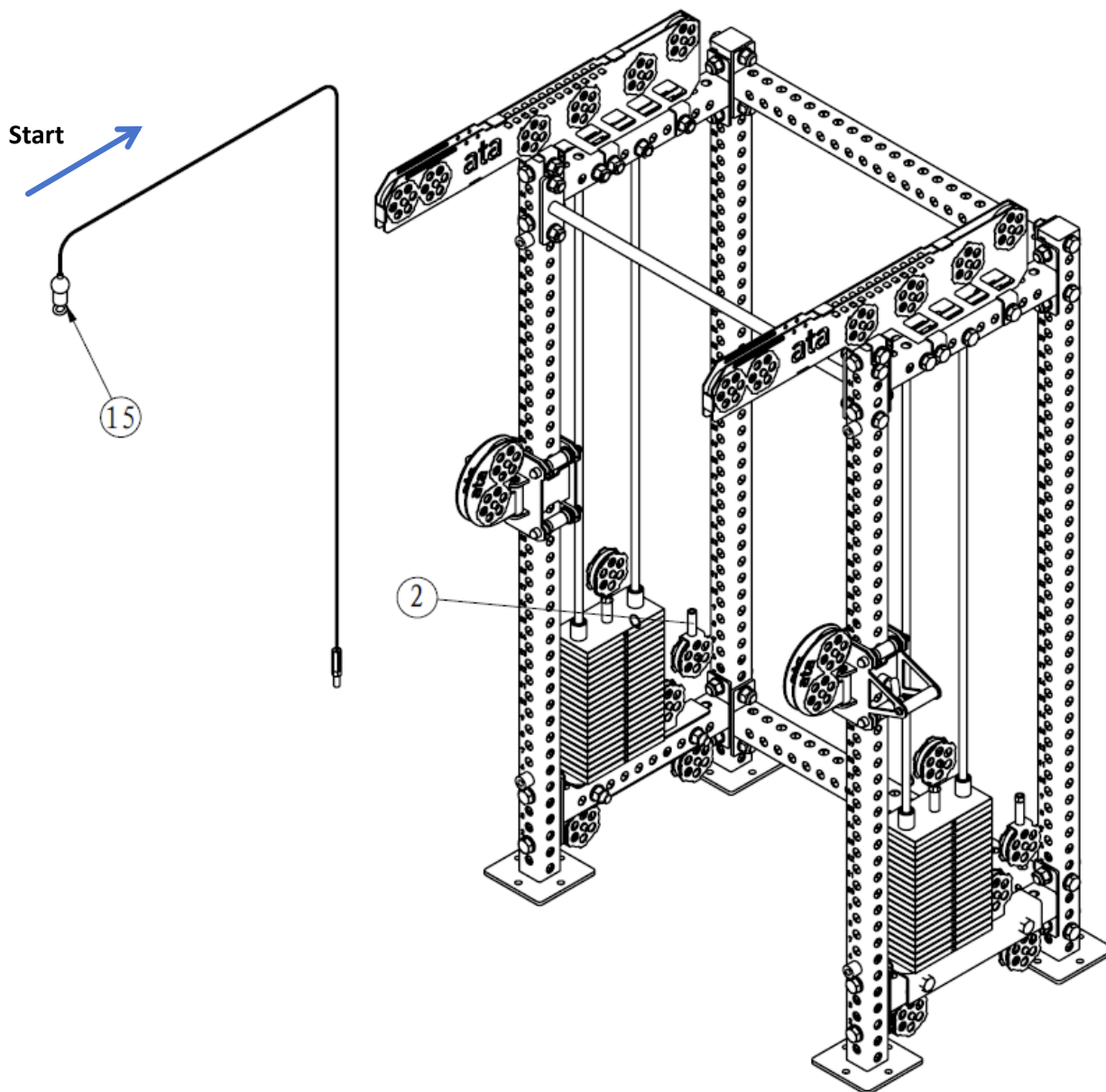

STEP 9 Install seated cable row cable

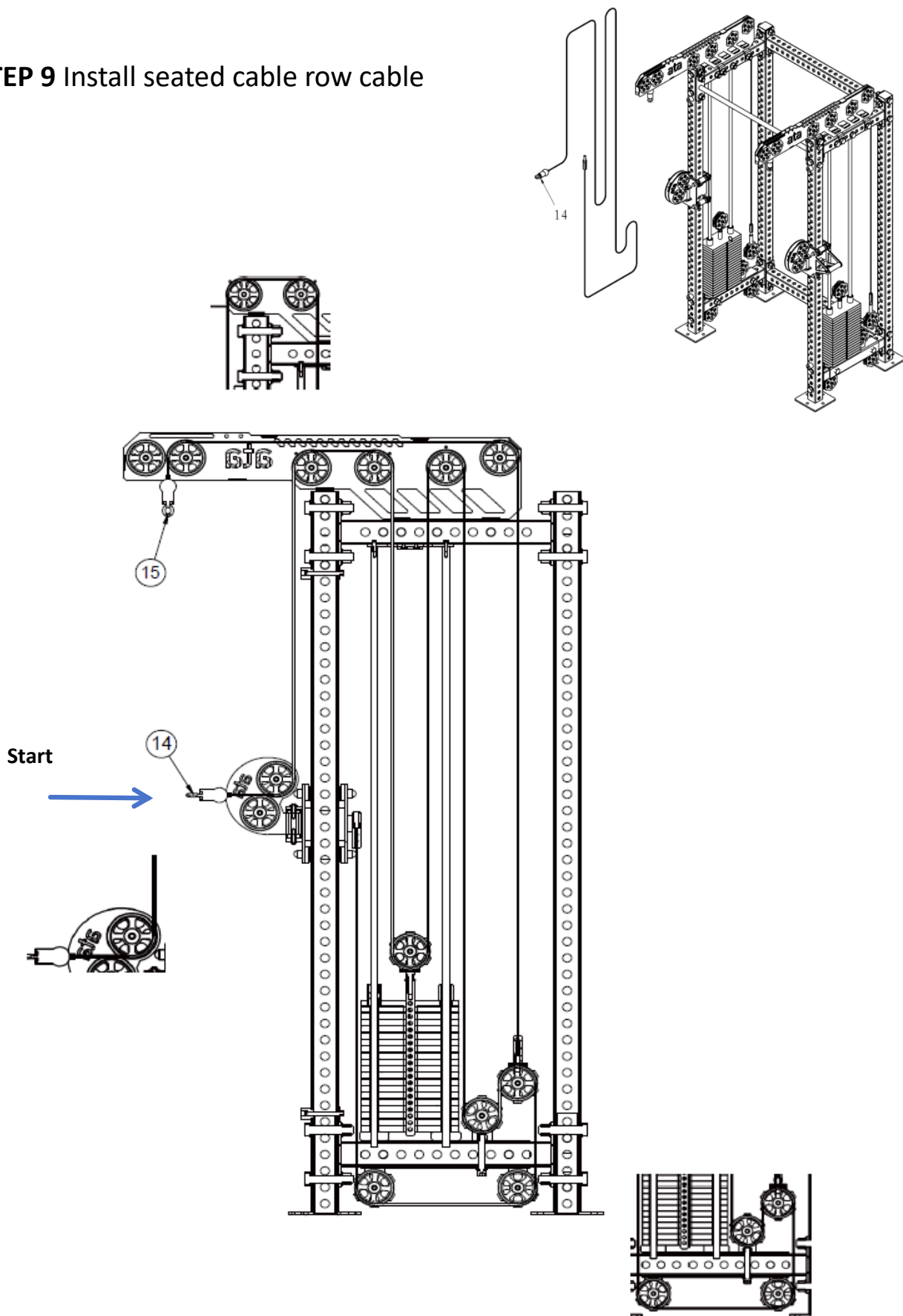

Monteringsansvisning for endehylse med rotasjon

- Hver skrue strammes 8-9 Nm. Det betyr hardt!
 - Steg 1. Løsne skruen som holder dekselet
 - Steg 2. Tre gummidelen + deksel inn på vaieren
- Steg 3. Stram skruene i rekkefølgen nedenfor, før du setter dekselet på plass

REKKEFØLGEN ER AVGJØRENDE!

1. Den innerste skruen strammes først (1/3).

2. På motsatt side strammer du neste (2/3)

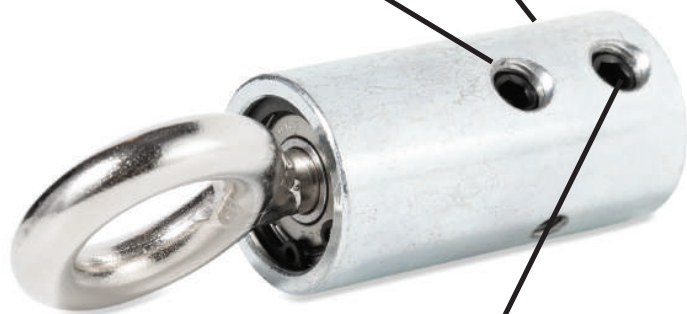

3. Siste skruen du strammer (3/3)

Sjekkliste

- Jeg har fulgt monteringsanvisningen
- Resultatet ser likt ut som bildet til høyre
- Vaieren er hel og uten synlige merker/skader
- Jeg har gjort gjentakende tester av apparatet med ny vaier



Serienummer: _____ Montert dato: _____

Dato for neste kontroll: _____ Signatur: _____

Dersom du ikke følger anvisning eller kontrollerer din vaier jevnlig så kan det lede til personskade!